

FlexiROC T35

Surface drill rig for quarrying and construction

Hole diameter: 64–115 mm (2.5"–4.5")



A flexible for rig for all occasions

Offering both efficient and flexible production, the FlexiROC T35 is hard to beat when working in quarries or construction sites.

FlexiROC T35 is a flexible and versatile tophammer drill rig, developed and designed for high performance in demanding construction applications. It is also a very efficient alternative for small and medium size quarrying. Even in rough terrain, utilization of the rig remains high, thanks to the long reach of the boom and the low center of gravity. It is equipped with a highly-efficient Epiroc rock drill to help ensure boost output and productivity.



⊕ Main benefits

Optimal use of rock drill and increased tool life thanks to a cylinder-operated feed system

Long boom reach making the rig ideal for demanding construction jobs

Supreme productivity thanks to proven COP rock drill series

Tough and dependable

This rig is built Epiroc solid. Thanks to a high degree of commonality with other Epiroc surface drill rigs and a world-wide service network, spare parts and consumables are there when you need them to ensure continuous uptime and great performance.



+ Flexible and efficient rock drill

COP rock drill has an easily changeable stroke setting. This makes it simple to change the frequency of the rock drill so it operates efficiently in different rock conditions. The rock drill also includes a double dampening system which makes it highly efficient in different kinds of rock. This system also minimizes the wear on the drill string which reduces costs further.



+ Proven design

FlexiROC T35 features a well-proven design which draws on many years of experienced in mining and construction. The FlexiROC T35 has produced sustainable results for a number of years and has many satisfied customers all around the globe.



+ Safety

The ROPS and FOPS-approved cabin provides both comfort and safety. Reliable and fast rod handling makes operation fast and efficient. A smooth and a rigid drill rod support decreases hole deviation for more accurate and higher quality holes. Additionally, maintenance is convenient due to a well thought out and efficient design. A FlexiROC T35 can be relied upon to get the job done — whatever the weather or ground conditions.

A comprehensive service offering

Even the best equipment needs to be serviced regularly to make sure it sustains peak performance. An Epiroc service solution offers peace of mind, maximizing availability and performance throughout the lifetime of your equipment. We focus on safety, productivity and reliability.

By combining genuine parts and an Epiroc service from our certified technicians, we safeguard your productivity – wherever you are.



Technical specifications

Main Components

- Track frames with single grouser pads and cleaning holes.
- Hydraulic track oscillation and two speed traction.
- Atlas Copco screw type compressor
- ROPS and FOPS-approved cabin
- LED work lights.
- Folding boom system.
- Aluminum profile feed beam
- Hydraulic cylinder feed system
- Carousel type rod handling system, 1 + 7 rods.
- Hydraulic rock drill.
- Dust collection system.
- Dust pre-separator.
- Double hydraulic drill rod support with movable down support.
- Service lamp inside canopy.
- Rock drill oil collecting system.
- Rubber skirt for DCT.
- COP Logic.

Hole range (recommended)

	Metric	US	US
Hole diameter	Ø 64–115 mm	Ø 2.5"–4.5"	T38, T45, T51
Hydraulic rod handling system for max hole length, with 3.6 m (12') ext. rods	28 m	92'	T38, T45, T51
Hydraulic rod adding system for max hole length, with 6.1 m + 4.2 m (20' + 14') - FlexiROC T35 -LF	10 m	33'	T38, T45, T51

Hydraulic rock drill

Rock drill	Hole diameter		Impact power	Hydraulic pressure, max		Impact rate, max	Torque, max		Weight approx	
COP SC19	Ø 64–115 mm	Ø 2.5"–4.5"	19 kW/25.5 hp	230 bar	3 336 psi	42/50 Hz	1 970 Nm	1 453 lbf/ft	188 kg	384 lb
COP SC19X									250 kg	551 lb
COP SC25-HF	Ø 64–89 mm	Ø 2.5"–3.5"	25 kW/33.5 hp	240 bar	3 481 psi	55/71 Hz	1 550 Nm	1 143 lbf/ft	189 kg	417 lb
COP SC25X-HF									250 kg	551 lb

Engine

Caterpillar turbo charged diesel engine	
CAT C7.1 Tier 4 Final/Stage 5 (EU/US cert.)	168 kW/225 hp
CAT C7.1 Tier 3/stage IIIA	(at 2 200 rpm)

Compressor

Atlas Copco OIS K-36-C111GD, screw compressor	Metric	US
Working pressure, max	10.5 bar	152 psi
FAD, at normal working pressure	127 L/s	270 cfm

Feed

	Metric	US
Feed extension	1 400 mm	55'
Feed rate, max	0.92 m/s	184 ft/min
Feed force, max	20 kN	4 400 lbf
Tractive pull, max	20 kN	4 400 lbf
Total length	7 140 mm	281'
Travel length	4 240 mm	167'

Electrical system

Voltage	24 V
Batteries	2 x 12 V, 185 Ah
Alternator	28 V, 95 Ah
Work lights, front	4 x 70 W
Work lights, rear	2 x 70 W
Work lights, feed	2 x 70 W
Warning lamp and reverse buzzer	

Volumes

	Metric	US
Hydraulic oil tank	250 l	65.0 gal
Hydraulic system, total	300 l	79.0 gal
Compressor oil	24 l	6.3 gal
Diesel engine oil	28 l	7.4 gal
Diesel engine, cooling water	35 l	9.2 gal
Diesel engine, fuel tank	370 l	98.0 gal
Traction gear	3 l	0.8 gal
Lubrication tank (ECL)	10 l	2.6 gal

Dust collector DCT 110

	Metric	US
Filter area	11 m ²	118 sq.ft
Suction capacity at 500 mm wg	560 L/s	1 200 cfm
Suction hose diam	127 mm	5"
Cleaning air pressure, max	7.5 bar	109 psi
Cleaning air consumption	2–4 l/pulse	0.06–0.12 cu.ft/pulse
Number of filter elements	11 pcs	

Hydraulic system

Return and drainage filters (filtration rate)	16 µm absolute
Hydraulic oil cooler max ambient temperature	50°C (122°F)



Safety cabin

- ROPS and FOPS approved with rubber vibration dampers
- 2 x wipers with washer
- Clear laminated glass (10 mm front and roof windows)
- Fully adjustable operator seat
- Cabin light
- Rig inclination indicator
- Rear view mirror
- Fire extinguisher, 6 kg (13 lbs) dry chemical type ABE class III type
- Outlet socket, 24 V
- Clear laminated glass (8 mm side window)
- Prepared with speakers for CD-radio or DVD radio
- Clear toughened glass (8mm rear window)
- Combined front mounted platform/tool box
- Electrical heated chair
- Cab heating

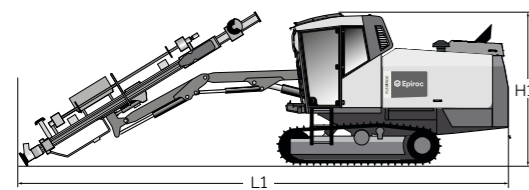

Feed dumped 1

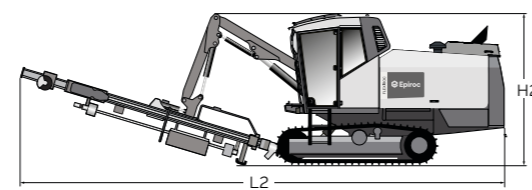

Feed dumped 2

Transport dimensions

Feed dumped 1	Metric	US
Height (H1)	3 200 mm	126.0'
Length (L1)	11 600 mm	456.7'
Feed dumped 2		
Height (H2)	3 500 mm	133.9'
Length (L2)	11 000 mm	433.1'

Weight

Standard unit excluding all options and drill rod	Metric	US
Tier 3 engine	15 500 kg	34 170 lb
Tier 4 Final engine	15 300 kg	33 730 lb

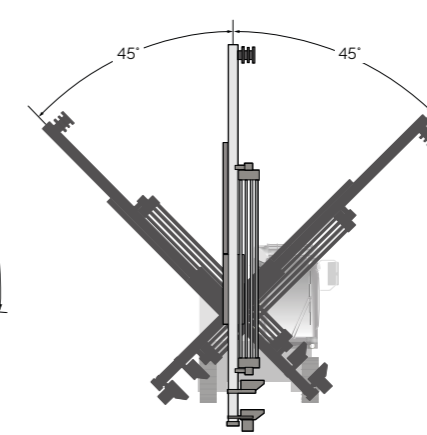
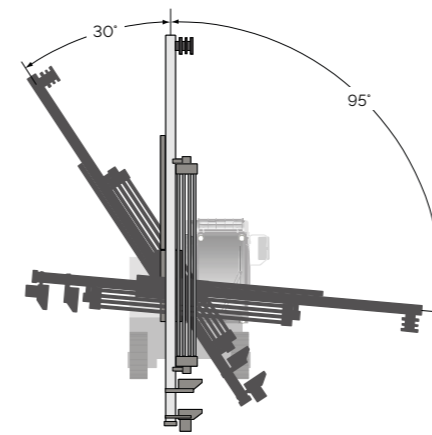
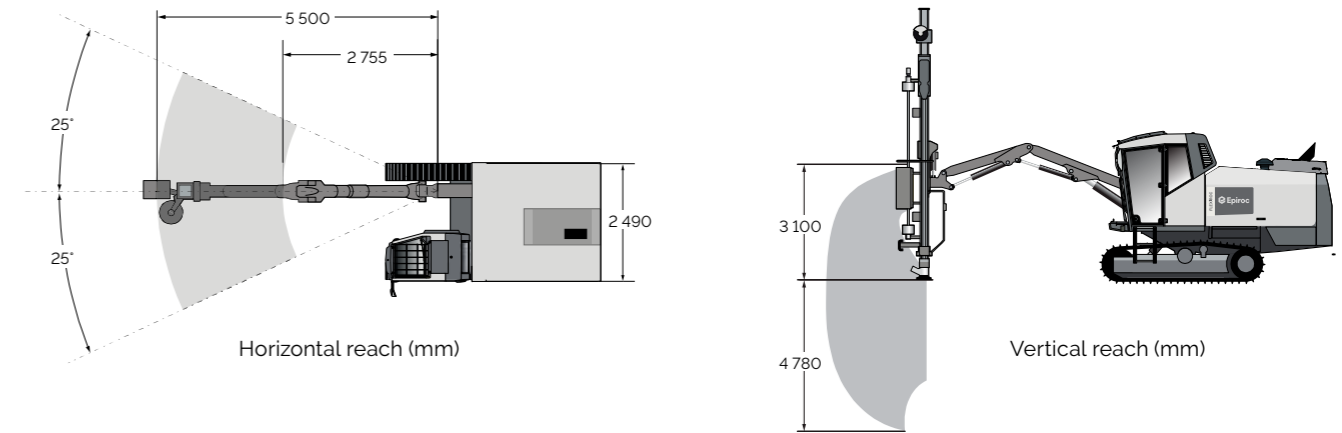

FlexiROC T35 -LF

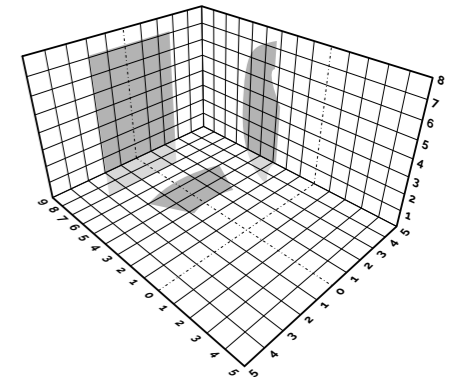

3D coverage area

Selection of options

Cabin

- Window panes: Laminated 24 mm clear front, 10 mm roof and 8 mm tinted side – toughened 8 mm rear
- Tinted 10 mm roof window
- Window wiper, right hand window
- Sun shade kit (rear side, rear windows and roof)
- Reverse camera with cab mounted display
- Radio with CD player
- Camera for support leg

Carrier

- Hydraulic support leg
- Hydraulic winch including wire with towing eye and wire guides
- Diesel-driven engine heater
- Electric fuel filling system
- Tow hook
- Track chains with triple grouser pads
- Rubber disc for DCT
- PAR oil M & S

- Central lubrication system
- Tool box left rear side
- Extra air outlet on front of the carrier
- Xenon work lights
- Air flow switch

Feed

- Protective guard, according to EN16228
- Bigger Dowel with big plate to avoid sinking in soft ground
- TDS guide tube guides for drill rod support:
 - TDS 56 for 56 mm guide tube
 - TDS 64 for 64 mm guide tube
 - TDS 76 for 76 mm guide tube
 - TDS 87 for 87 mm guide tube
- Support bracket RHS carousel
- Thread greasing device ECG (with oil)
- Thread greasing device, brush type (with grease)
- Sleeve retainer

Water system

- Complete water mist system 120 l tank

Hole and inclination systems

- Hole inclination/depth instrument HQS11
- Laser plane receiver for hole depth HQS12
- GPS compass aiming unit
- Mechanical hole inclination instrument ROC angle

Parts and Services

- COP Care
- ROC Care

Optional equipment not mounted

- Gas charging equipment for rock drill
- First 50 hours service kit for compressor
- Lubrication system
- Conversion kit T38, T45, T51

United in performance. Inspired by innovation.

Performance unites us, innovation inspires us, and commitment drives us to keep moving forward. Count on Epiroc to deliver the solutions you need to succeed today and the technology to lead tomorrow.
[epiroc.com](https://www.epiroc.com)

