

Boomer T1

Single-boom face drilling rig for narrow drifts and tunnels with cross sections up to 23 m²



Prime performance packed into a small, versatile unit

The Boomer T1 is an ideal rig for narrow vein mining. It can be quickly and accurately set up for work in any geotechnical conditions and can be equipped with boom suspension for safer tramming and less wear on parts. The rig can be fitted with a variety of COP rock drills so you can select one ideally suited to your requirements. To further increase the versatility of the rig, it can be equipped with a supplementary drilling kit for long-hole drilling. Boomer T1 has proven popular with operators in diverse work areas throughout the world.

+ Main benefits

Suitable for mines with small drift sizes thanks to its small envelope and the ability to get into places where hand-held equipment may have been used in the past

Outstanding drill steel economy with the COP MD20, COP 1638HD+, COP 1838HD+ and COP 2238HD+ rock drills that feature dual damping for efficient, high-speed drilling and greater drill steel longevity

Safety and control thanks to a FOPS certified telescopic protective roof or an ergonomically designed ROPS and FOPS certified cabin which ensures safety, excellent visibility and surveillance for the operator

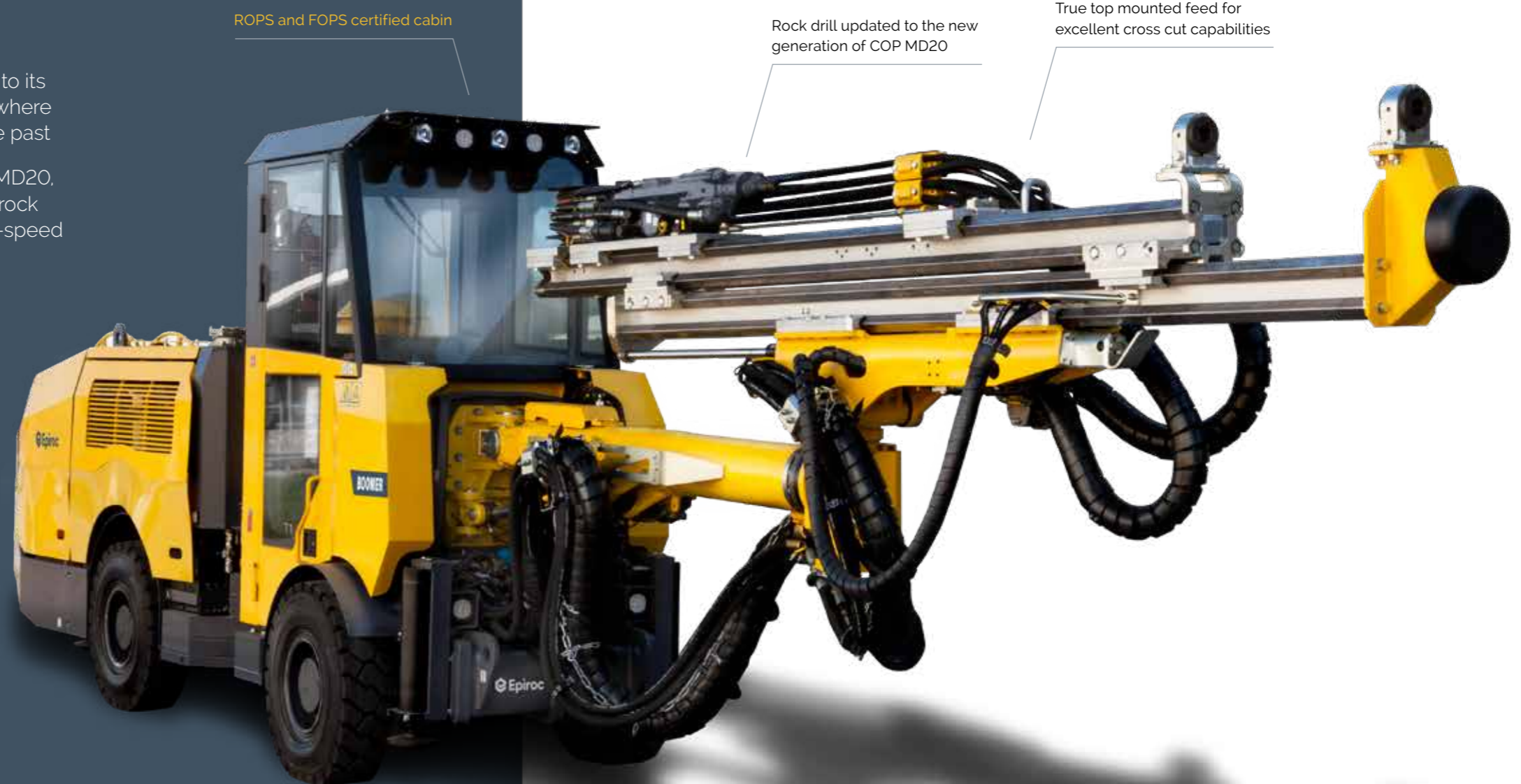

ROPS and FOPS certified cabin

Rock drill updated to the new generation of COP MD20

True top mounted feed for excellent cross cut capabilities

Packs a punch in narrow drifts and tunnels

The Boomer T1 has been specially engineered to suit smaller, narrower drifts and tunnels with cross sections up to 23 m². The carrier features high ground clearance as well as spring applied hydraulic release brakes. For maximum durability, the rig is equipped with a heavy-duty aluminium feed with high bending and torsional resistance.



+ Certified power and performance

The rig is powered by a 4-cylinder diesel engine that concurrently offers powerful performance and low emissions to reduce environmental impact. The engine is available with stage IIIA certification.

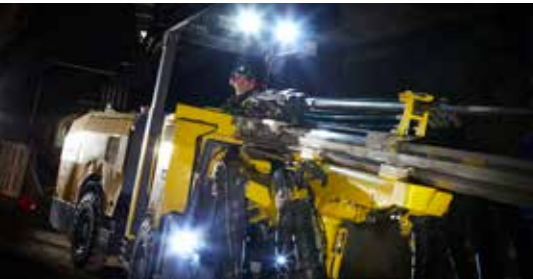

+ Easy to operate and maintain

The operator can enjoy an ergonomically designed cabin with a user-friendly interface to easily monitor and control all rig functions. The rig is also cleverly designed to provide straightforward access to all service points for easy maintenance.



+ The COP MD20 series

Rock drills in the COP MD20 series provide separate lubrication of driver and gear as well as pressurized side bolts and mating surfaces for reliable operation, low maintenance costs and long intervals between overhauls. The variable and reversible rotation motor ensures high torque with exceptional speed control.



A comprehensive service offering

Even the best equipment needs to be serviced regularly to make sure it sustains peak performance. An Epiroc service solution offers peace of mind, maximizing availability and performance throughout the lifetime of your equipment. We focus on safety, productivity and reliability.

By combining genuine parts and an Epiroc service from our certified technicians, we safeguard your productivity – wherever you are.

Technical specifications

● - Standard ○ - Option

Drilling system

COP MD20	○
COP 1638HD*	○
COP 1838HD*	○
COP 2238HD*	○
Water mist flushing, external water and air supply (water or air oil cooler)	○
Hole blowing kit	●
Rock drill lubrication warning kit	●
Big hole drilling system	●

Boom

BUT 4	●
Automatic boom lubrication kit (rear part of the boom)	○
Boom suspension system	○
Long Hole Drilling system (manual rod handling), including BMH or BMHS 2000 series production feed (1.2, 1.5 or 1.8 m extension steels), BSH 45 drill steel, rear stinger, FAM T1 angle reading instrument	○

Feed

BMH 2825, drill steel length 2 500 mm	○
BMH 2831, drill steel length 3 090 mm	○
BMH 2837, drill steel length 3 700 mm	○
Telescopic feed BMHT 2000-series (max 3.7 m)	○
Extension drilling set BSH 110 (BMH feeds only)	○
Bulk head style hose tree on feeds	○

Air/water system

Hydraulic water booster pump capacity at 12 bar, 66 l/m	●
Compressor: Atlas Copco LE7	●

Hydraulic system

Low oil level indicator	●
Oil temperature meter	●
Filtration 16 µm	●
Oil filter indicator	●
Mineral hydraulic oil	●
Electric oil filling pump	●
Water/oil cooler in stainless steel	●
Hydraulic oil thermostat	○
Ni-Cr plated piston rods (limitations exist)	○
*Only with water cooled diesel engines	

Control system

Direct Control System (DCS2)	●
Feed Angle Measurement, FAM T1 (including electronic parallel hold)	○

Electrical system

Total installed power 59 kW*	●
Total installed power 79 kW*	○
Main motors 55 kW*	●
Main motors 75 kW*	○
Voltage 380-1 000 V	●
Frequency 50 Hz - 60 Hz	○
Starting method star/delta 380-690 V, direct start 1000 V	●
Starting method - soft start (not for 1000 V)	○
Transformer 4 kVA	●
Electronic overload protection for electric motors	●
Percussion hour meter	●
Digital volt/ampere meter in electrical cabinet	●
Phase sequence and eart fault indicator	●
Battery charger	●
Dual controls for cable reel	●
Electrical cable (Buflex)	○
Connector	○
Plug PC4/PC5	○
Socket PC4/PC5	○
Switch gear	○

*Larger powerpacks may be used at high altitude or with certain options.

Carrier

Deutz D914 L04, EPA III/COM III, Stage IIIA/Tier 3, 55 kW	●
Deutz TCD 2.2 L03, Stage V, 55.4 kW	○
Deutz TCD 2.2 L03, CN4, 55.4 kW	○
Articulated ±40° steering angle	●
Four wheel drive	●
Electrical system 24 V	●
Batteries 2x12 V, 70 Ah	●
Working lights, 3x80 W LED, 24 V DC	●
Tramming lights, 8x40 W LED, 24 V DC	●
Illuminated stairs	○
Automatic differential lock on front axle	●
Tires, 8.25xR15	●
Clearance outside axles rear 15°	●
Front and rear hydraulic jacks	●
Fuel tank volume, 4-cylinder engine: 60 l	●
Manual lubrication kit	○
Fire suppression system ANSUL (manual, checkfire or automatic)	○
Rig washing kit	○
Shelf for bits and tools	○
Holder for spare drill rods	○
Cold weather package	○

Technical specifications

● - Standard ○ - Option

Cabin (optional)

ROPS/FOPS approved airconditioned cabin, noise level <80 dB(A)	●
Media player	●
12 V outlet	●
Joystick controlled spot light, 70 W (roof mounted)	●
Fixed seat	●
Front window, 16 mm	●
Front window, 24 mm	○
Air condition (cooling only)	●

Protective roof

Fixed seat	●
FOPS approved	●
Manual spotlight	○
12 V outlet	●

Drill rods

Dimension	Minimum hole diameter
R38-H35-R32	45 mm
R38-H35-SR35 speedrod	45 mm
T38-H35-R32	45 mm
T38-H35-R32 speedrod	45 mm
T38-H35-SR35	45 mm
T38-H35-R35	48 mm
T38-H35-R35 speedrod	48 mm
T38-R39-R35	48 mm
T38-R39-SR35	45 mm
T38-R38-R35	48 mm

Extension rods for injection drilling/RAS

Dimension	Minimum hole diameter
R32 speedrod	51 mm
T38 speedrod	64 mm

Shank adapters

Thread	Diameter	Length
R38	38 mm	435 mm
T38	38 mm	435 mm
R32	38 mm	525 mm
T38	38 mm	525 mm

Couplings

Thread	Diameter	Length
R38	55 mm	170 mm
T38	55 mm	190 mm

Recommended cable sizes and lengths (75 kw)

Voltage	Dimension, mm ²	Diameter, mm	Length, mm
380-400 V	3x70+3G16+2x1.5	37	110
440 V	3x70+3G16+2x1.5	37	110
500-525 V	3x70+3G16+2x1.5	37	110
550-575 V	3x50+3G6+2x1.5	32	150
660-690 V	3x35+3G6+2x1.5	28	200
1 000 V	3x35+3G6+2x1.5	28	200

Recommendations are given for surrounding temperature of 40°C.

Recommended cable sizes and lengths (55 kW)

Voltage	Dimension, mm ²	Diameter, mm	Length, mm
380-400 V	3x50+3G10+2x1x1.5	39	150
440 V	3x50+3G10+2x1x1.5	39	150
500-525 V	3x35+3G6+2x1x1.5	33	200
550-575 V	3x35+3G6+2x1x1.5	33	200
660-690 V	3x35+3G6+2x1x1.5	33	200
1 000 V	3x35+3G6+2x1.5	28	200

Recommendations are given for surrounding temperature of 40°C.

Dimensions

Width	1 300 mm
Height, roof down	2 024 mm
Height, roof up	2 726 mm
Cabin height (option)	2 716 mm
Length, tramming	9 651 mm BMH 2837
Ground clearance	296 mm
Turning radius outer/inner	4 400/2 750 mm

Weight

Total	11 000 kg
Boom side	7 100 kg
Engine side	3 900 kg
Depending on configuration	

Noise and vibration

Operator sound pressure level in canopy, drilling, free field (ISO 11201)	103±6 dB(A) re 20 uPa
Operator sound pressure level in cabin, drilling, free field (ISO 11201)	80±5 dB(A) re 20 uPa
Operator sound pressure level working close to machine, drilling, free field	103±6 dB(A) re 20 uPa
Sound power level (ISO 3747), drilling, free field	123 dB(A) re 1 pW
Peak C-weighted instantaneous sound pressure level (EN16228)	Less than 130 dB
Vibration levels seated, drilling (ISO 2631-1) (cabin)	0.07±0.07 m/s ²
Vibration levels standing, drilling (ISO 2631-1) (cabin)	0.07±0.07 m/s ²
Vibration levels seated, drilling (ISO 2631-1) (canopy)	0.15±0.15 m/s ²
Vibration levels standing, drilling (ISO 2631-1) (canopy)	0.15±0.15 m/s ²

Technical specifications

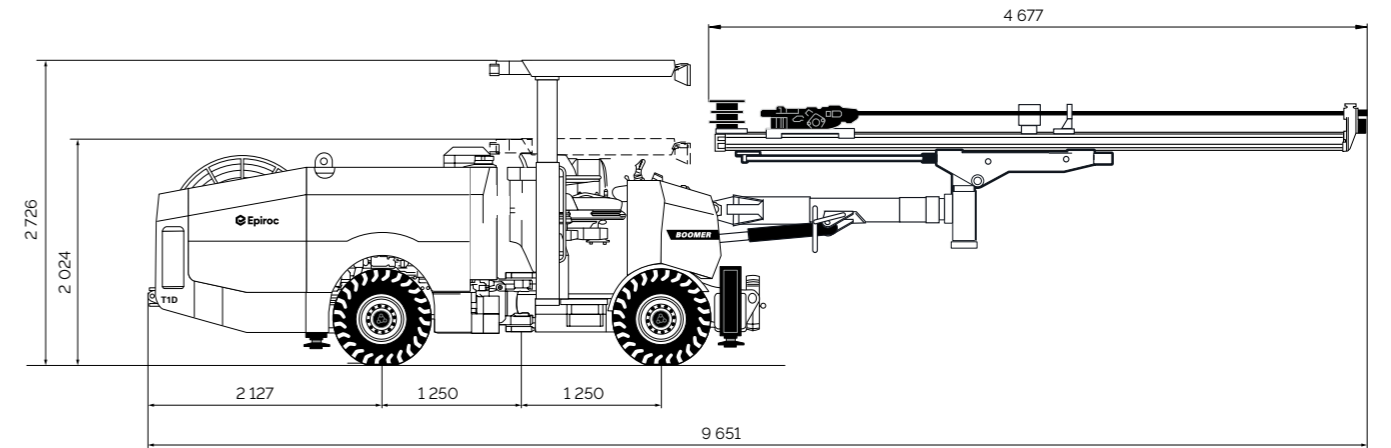

Dimension illustration, optional equipment mounted (dimensions in millimeters).

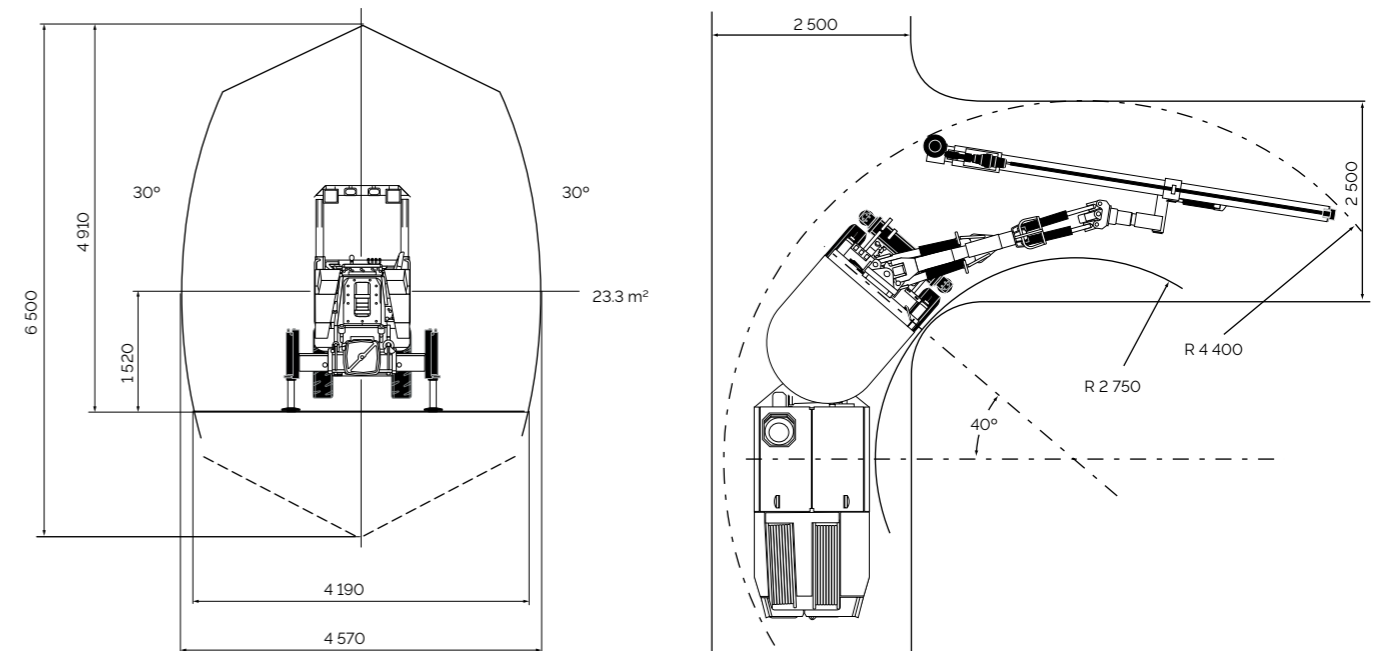

Coverage area (dimensions in millimeters unless other specified).

Turning radius (dimensions in millimeters unless other specified).



9869 0055 01b 2022-02 Orebro, Sweden. Legal Notice: Copyright © 2022 Epiroc Rock Drills AB Orebro, Sweden. Any unauthorized use or copying of the contents or any part thereof is prohibited. Illustrations and photos may show equipment with optional extras. No warranty is made regarding specifications or otherwise. Specifications and equipment are subject to change without notice. Consult your Epiroc Customer Center for specific information.

United in performance. Inspired by innovation.

Performance unites us, innovation inspires us, and commitment drives us to keep moving forward. Count on Epiroc to deliver the solutions you need to succeed today and the technology to lead tomorrow.
[epiroc.com](https://www.epiroc.com)

